

THE INFORMATION CONTAINED IN THIS DRAWING IS THE SOLE PROPERTY OF LEGACY TECHNOLOGIES, INC. ANY REPRODUCTION IN PART OR WHOLE WITHOUT THE WRITTEN PERMISSION OF LEGACY TECHNOLOGIES, INC. IS PROHIBITED.

REV	DESCRIPTION OF REVISION	E.C.N.	BY	APPROVED	DATE
A	CLASS STOP WAS .043 REF. EYELET REV. B ON 10-07-10		E.C.	E.T.W.	3-06-15

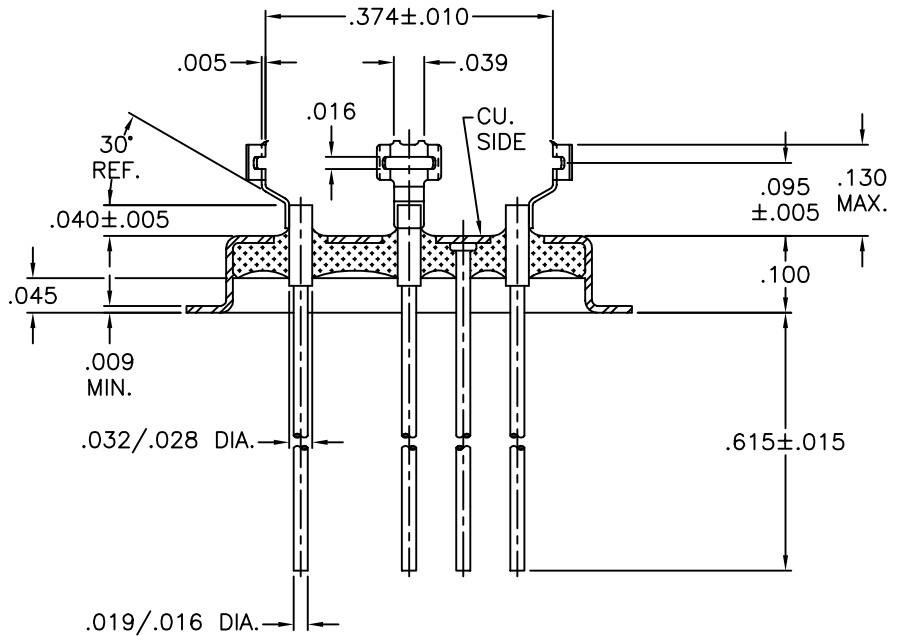
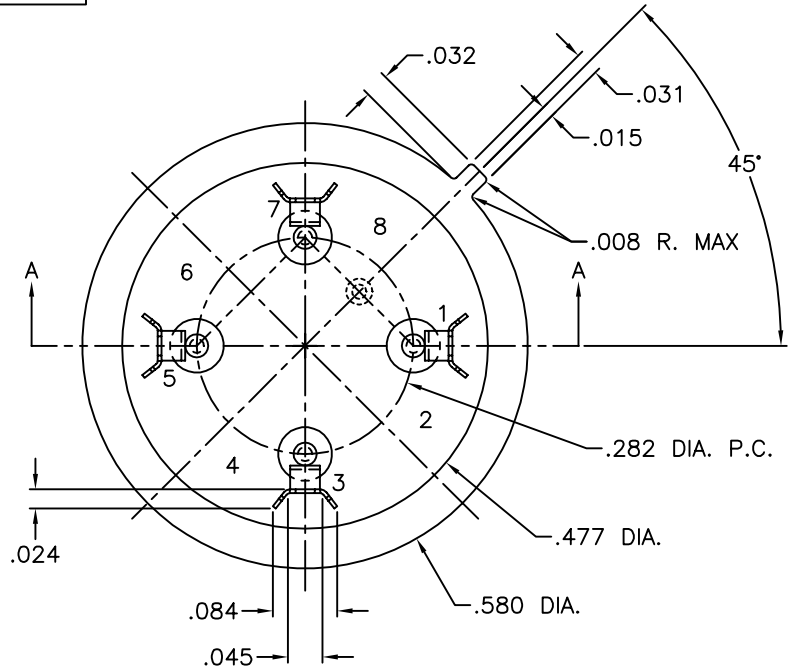

SECTION A-A

**MATERIAL:**

EYELET - 30/70 COPPER CLAD KOVAR.  
GLASS - 7052 OR EQUAL, OPAQUE.  
LEADS - ASTM F-15 ALLOY, KOVAR.  
MOUNT - 301 S.S., 1/2 HARD.

**PLATING:**

1. OPTION: RoHS COMPLIANT ELECTROLESS NICKEL PLATE OF 100 MICROINCHES MINIMUM FINAL PLATE.
2. OPTION: RoHS COMPLIANT ELECTROLESS NICKEL PLATE OF 100 MICROINCHES MINIMUM FOLLOWED BY A RoHS COMPLIANT LEAD FREE SOLDER COAT, ON LEADS ONLY.
3. OPTION: RoHS COMPLIANT ELECTROLESS NICKEL PLATE OF 100 MICROINCHES MINIMUM FOLLOWED BY A GOLD FLASH OF .99999 PURE 24 KART GOLD UP TO A MAX. OF 8 MICROINCHES.

DRAWN BY: E.T.W. 06-05-07		MATERIAL: SEE ABOVE		TOLERANCING PER ANSI Y14.5 .X ± .005 .XXX ± .005 .XX ± .005 ANG ± 5° UNLESS OTHERWISE SPECIFIED		 <b>Legacy Technologies Inc.</b> 6700 W. 47th TERR. MISSION, KS. 66203 TEL: 913-432-2487 FAX: 913-432-0570		
CHECKED BY: E.T.W. 06-05-07		APP. SPECS	SUPERSEDES	NEXT ASSY	SCALE: 4:1			FINISH: UNLESS OTHERWISE SPECIFIED <input checked="" type="checkbox"/>
APPROVED BY:		TITLE: HC-37/U (COLD WELD TO-8) W/ BH-CLIPS FOR .402 DIA. BLANK				FILE: HC00047A		PAGE 1 of 1